



## Financial Literacy: Auto Industry

### Auto Industry:

- Compare the economies of different communities, regions, or countries, including the influence of factors such as industries, access to resources and markets.
- Students will understand the effect of various factors on the auto industry in North America.

**First:**

- Discussion on economic systems (capitalism, Feudal, command, mixed)
- Factors that influence production (economic relationships, trading agreements, industrial development)
- KWL on economy and production
- Words: Production, economy, capitalism, feudal, command, mixed, supply and demand, imports, markets, exports, tariffs, goods and services, primary, secondary, tertiary sectors, land, trade, developed and underdeveloped, globalization, class, caste, NAFTA, free trade, WTO, globalization, migration, technology, inflation (Frayer Model---guess what the word is, look it up, synonyms, antonyms --- use Internet of dictionary and thesaurus)
- Life and Debt video
- Who Killed the Electric Car
- Label the parts of a car
- Label a map of North America
- KWL on automobiles
- Think-pair-share on auto industry (If automobile production in North America only took place in Mexico what would the effects be on North America?)



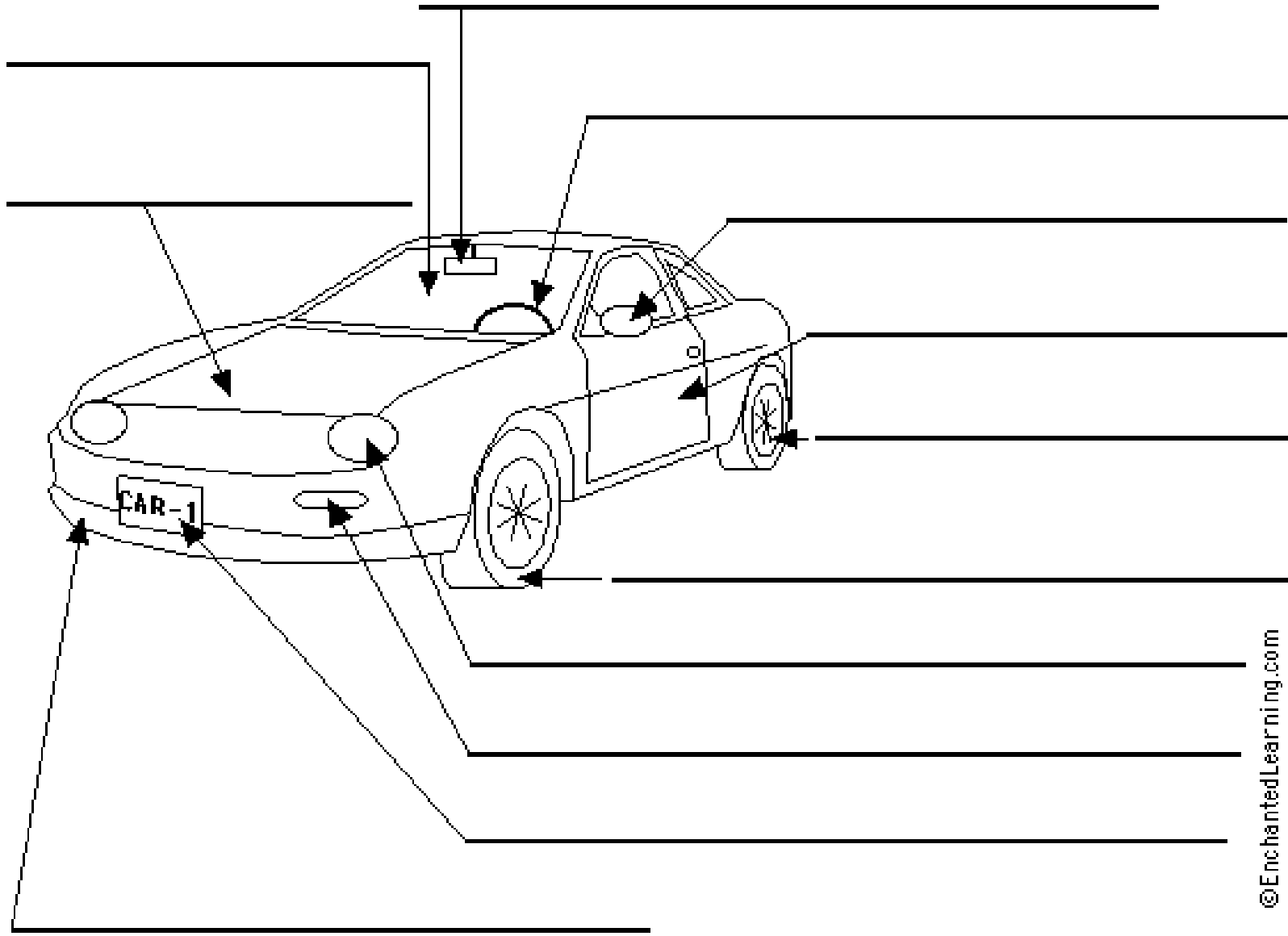
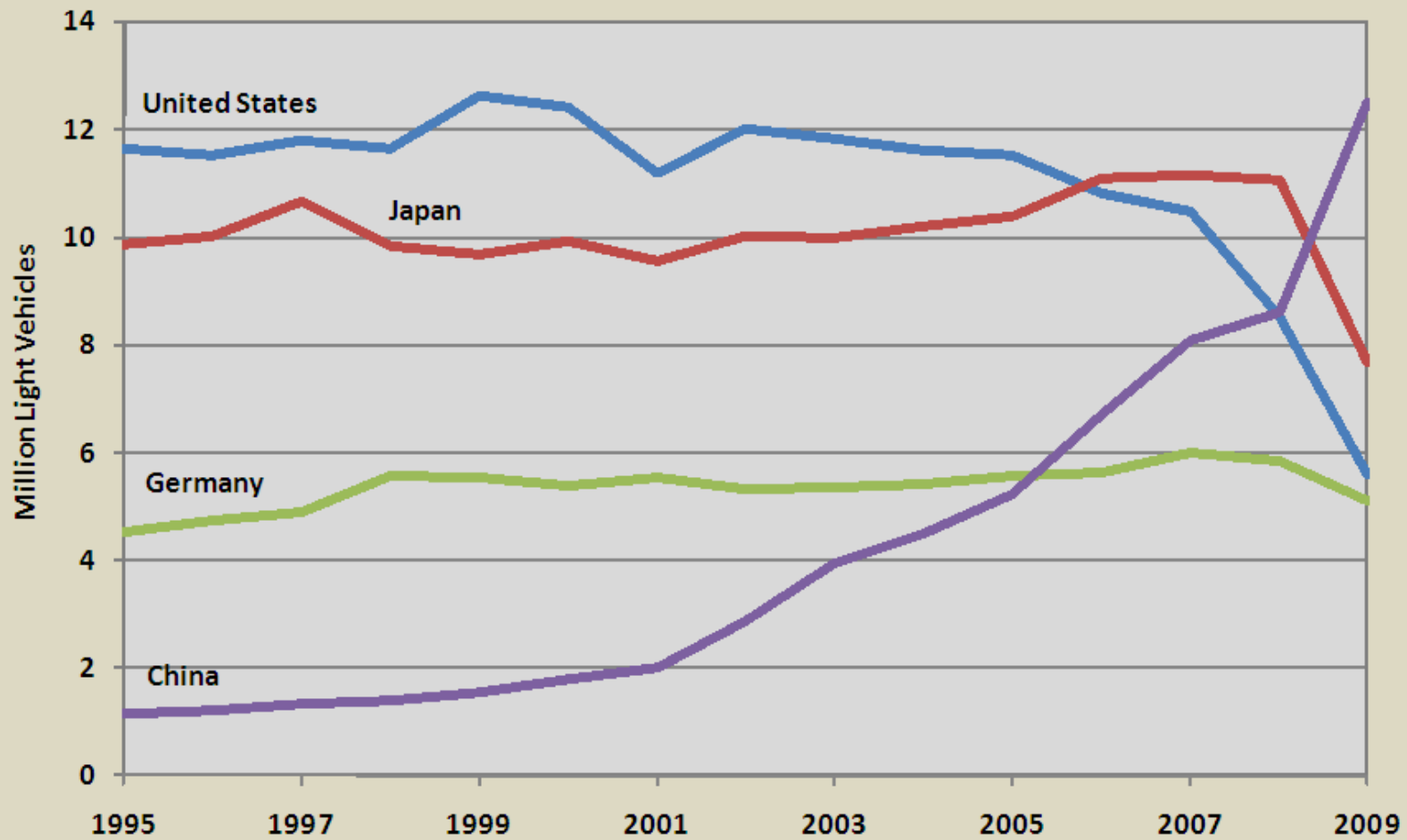
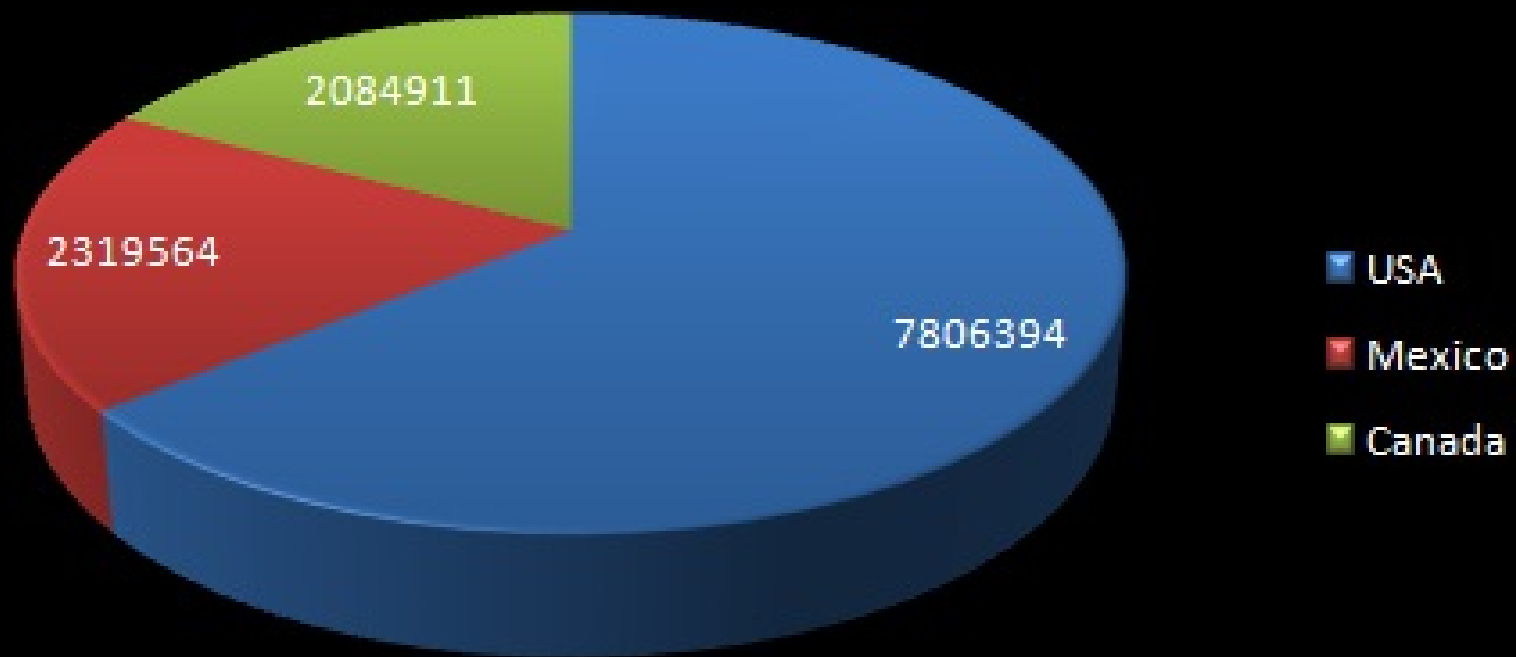

Figure 2. Light Vehicle Production, Leading Countries, 1995–2009





**2010 North American Auto Production**

## The Big Three and Canada

### Impact of Reduced Auto Production

The national and provincial/regional impact on GDP in terms of percent decline assuming a CAD1 billion drop in vehicle exports and a CAD1 billion drop in parts exports.

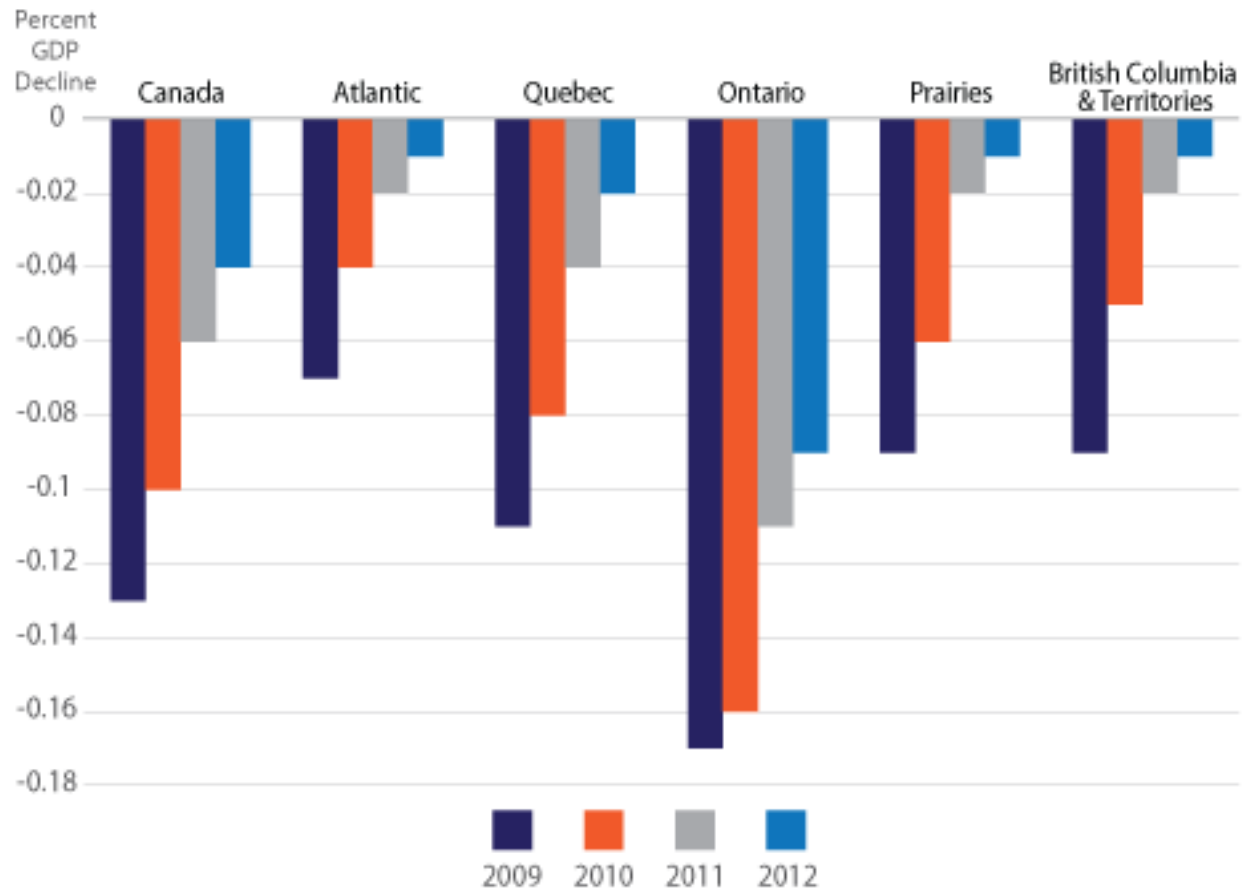

Sources: Informetrica, Toronto Globe and Mail, Canadian Edge Design: Steve Kizer

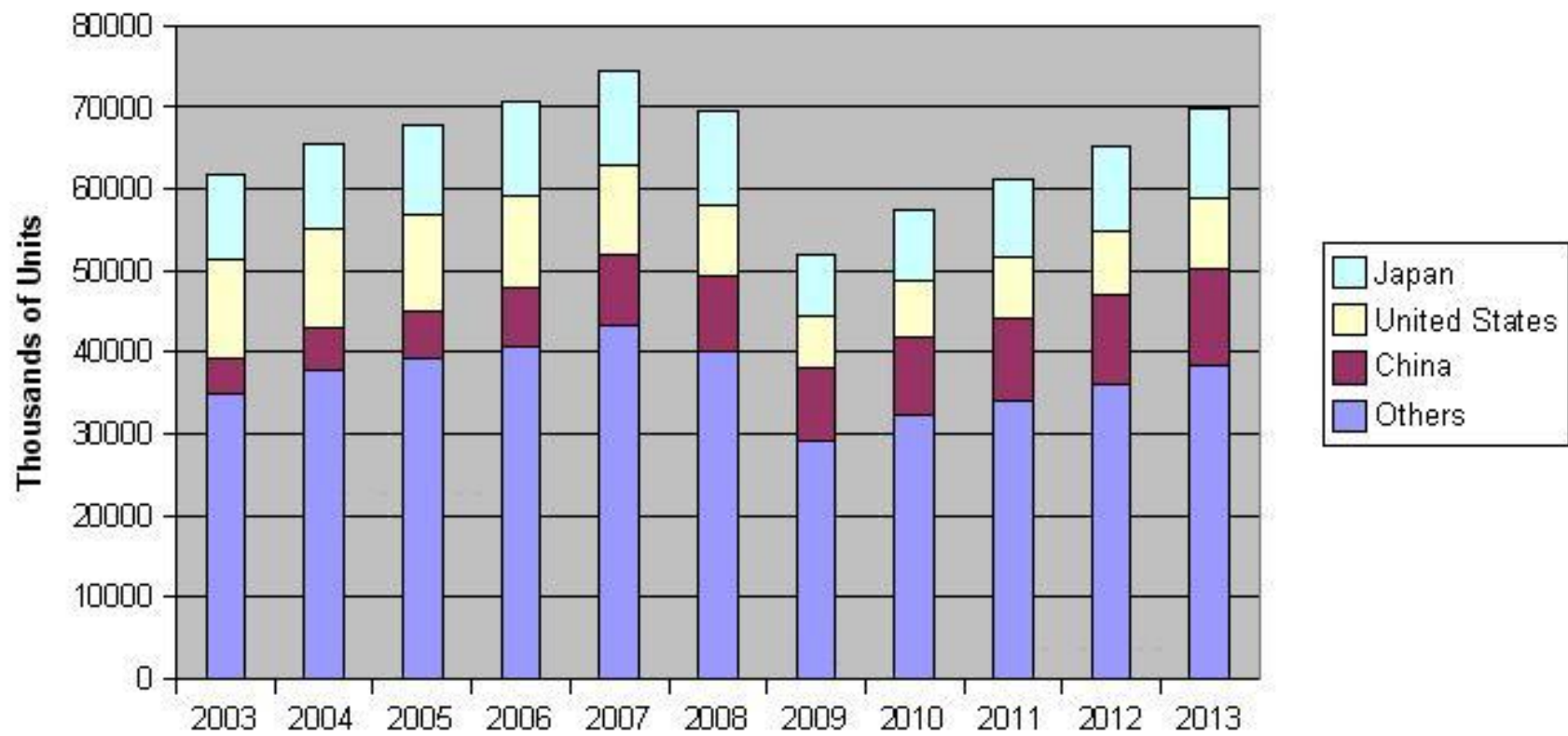





- 
- 
- 
- 
- 
- 
- 
- 

<http://www.ontario.ca/siteselection/WebPages/Dashboard/DashBoard.aspx>

[http:// Oica.net](http://Oica.net)

<http://www.cbc.ca/news/background/autos>

<http://www.cbc/news/canada/story/2008/10/21/f-autolayoffs.html>

### **YouTube –The Automotive Industry in Mexico:**

- Compare economies using a Venn diagram (advantages and disadvantages of the different economies – Venn Diagram (generate factors to investigate from class discussion on Life and Debt video and Terminology Frayer discussion)
- Research how technology changed production in the auto industry (consolidation, unemployment, information technology, Just in Time production, division of labour, de-unionization, pay equity)
- As they are researching, students will list the social effects that come up (unemployment, child labour, environmental destruction, poverty, wage lowering, class, growing wage disparity, union issues)---- EPI (Economic Policy Institute) NAFTA at Seven --- news paper articles
- Field trip to Oshawa auto plant and e-mail interview to industry expert (generate questions to ask)
- Field trip to the Metro Toronto Convention Center to see the Canadian International Auto Show in Feb.

**Look For (Success Criteria):**

- Use appropriate vocabulary (Inquiry/research and Communication)
- Be able to read and create different types of maps (Map skills – Application)
- Appropriately describe the relationship between various factors (Knowledge and Understanding and Application)
- Use a variety of primary and secondary sources to locate relevant information about the North American auto industry (map skills – application) Make accommodations for special needs - Adjust the amount of factors based on special needs
- Generate recommendations to ameliorate or solve social problems arising from auto production in North America
- Formulate relevant questions to guide their research (effects of technological change, NAFTA on auto production and social effects) (Inquiry/research and Communication)

**End Products:**

- Students will make a PowerPoint that outlines the factors that influence the auto Industry in North America (text, maps, graphs) and the current state of the industry
- Role play as a government official (or union official or IMF agent) who is in charge of economic development and make recommendations and present findings to the class.